

60L024B

Ø 60 mm • RoHS Compliant • 169.5 mNm

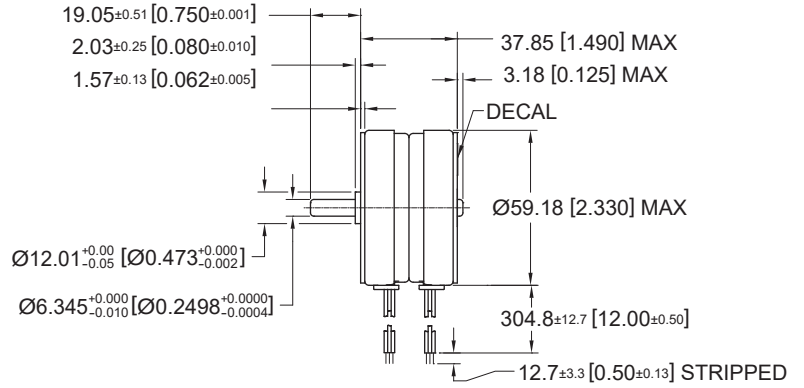
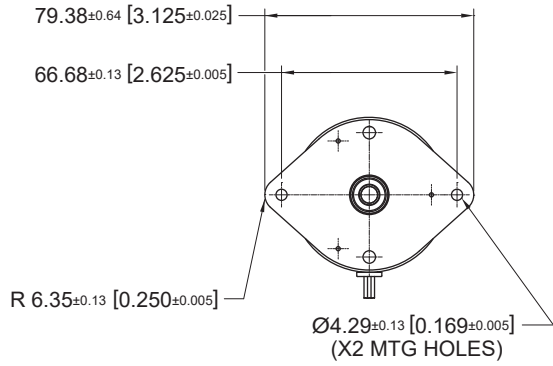

Dimensions in mm [inches]

Electrical Data	60L024B••				Unit
	1U Unipolar	2U Unipolar	1B Bipolar	2B Bipolar	
1 Operating Voltage	5	12	5	12	VDC
2 Resistance per Phase, ± 10%	4.6	26.2	4.6	26.2	Ohms
3 Inductance per Phase, typ	6.0	32.0	11.5	65.0	mH
4 Rated Current per Phase *	1.09	0.46	1.09	0.46	A
Coil Independent Parameters					
5 Holding Torque, MIN *	130.64 (18.5)	130.64 (18.5)	169.48 (24)	169.48 (24)	mNm (oz-in)
6 Detent Torque, Max	28.25 (4)				mNm (oz-in)
7 Rotor Inertia	95 (0.52)				gcm ² (oz-in ²)
8 Step Angle	15.0				Degree
9 Absolute accuracy 2 ph. On, Full step	± 1				Degree
10 Steps per Revolution	24				
11 Ambient Temp Range (operating)	-20 to +70 (-4 to +158)				°C (°F)
12 Maximum Coil Temperature	130 (266)				°C (°F)
13 Bearing Type	Sintered Bronze Sleeve				
14 Insulation Resistance at 500 VDC	100				Mohms
15 Dielectric Withstanding Voltage	650 VRMS for 2 seconds				VAC
16 Weight	440 (15.5)				g (oz)
17 Leadwire	AWG #24, UL1430 (105° C, 300 V)				

Note: All motor data values at 20° C unless otherwise specified
 * Engergize at rated current, 2-Phase On

