

P520

Ø 52 mm • 120 mNm

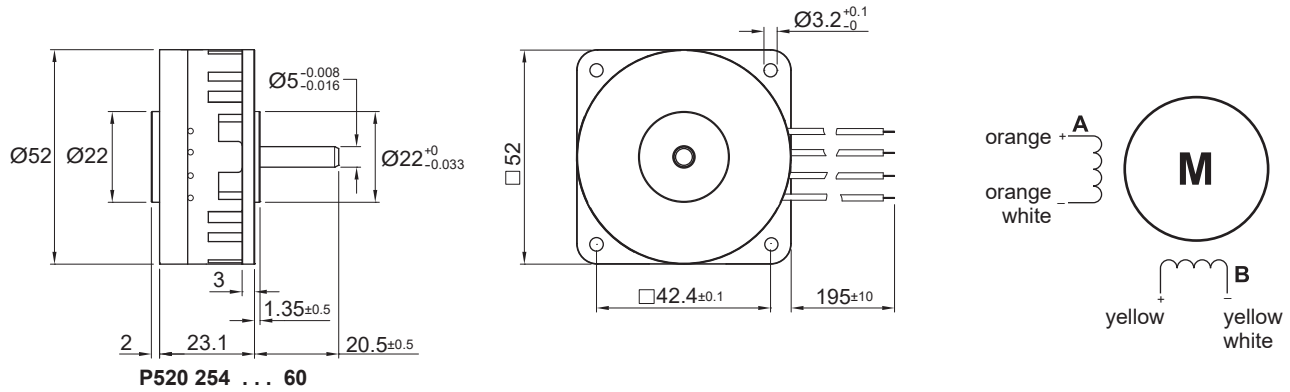

Dimensions in mm

Electrical Data	P520 254			Unit
	013 60	004 60	0.7 60	
1 Resistance per Phase, typ	13.5	4.4	0.7	Ohms
2 Inductance per Phase, typ	27.0	8.0	1.3	mH
3 Nominal Phase Current (2 ph. On)	0.50	0.90	2.30	A
4 Nominal Phase Current (1 ph. On)	0.75	1.30	3.30	A
5 Back EMF Amplitude	9.80	5.50	2.10	V/kstep/s
General Data				
6 Holding Torque, nominal current		120 (17)		mNm (oz-in)
7 Holding Torque, 1.5x nominal current (1)		170 (24)		mNm (oz-in)
8 Detent Torque		18 (2.55)		mNm (oz-in)
9 Rotor Inertia		12.000		kgm ² x 10 ⁻⁷
10 Step Angle		3.6		Degree
11 Absolute Accuracy 2 ph. On, Full step mode		+/- 5%		% Full Step
12 Steps Per Revolution		100		
13 Ambient Temperature Range (operating)		-20 to 50 (-4 to 122)		°C (°F)
14 Maximum Coil Temperature		130 (266)		°C (°F)
15 Thermal Resistance Coil-ambient (2)		9.5		°C/W
16 Natural Resonance Frequency (nominal current)		250		Hz
17 Electrical Time Constant		1.80		ms
18 Angular Acceleration (nominal current)		100,000		rad/s ²
19 Bearing Type		Ball		
20 Dielectric Withstanding Voltage		500 VRMS for 5 seconds		VAC
21 Radial Shaft Play		15@5N		µm
22 Axial Shaft Play		10@5N		µm
23 Maximum Radial Shaft Load		20 (72)		N (oz)
24 Maximum Axial Shaft Load (3)		30 (108)		N (oz)
25 Weight		180 (6.3)		g (oz)
26 Power Rate (nominal current)		12.0		kW/s

Notes:

1. Measured with 1 phase ON. The max coil temperature must be respected
2. Motor unmounted
3. Shaft must be supported when press-fitting a pulley or pinion

