

B0912N1016 Small Bone Orthopedic Drill

Ø 0.872 inch • Brushless Slotted • 9.6 V

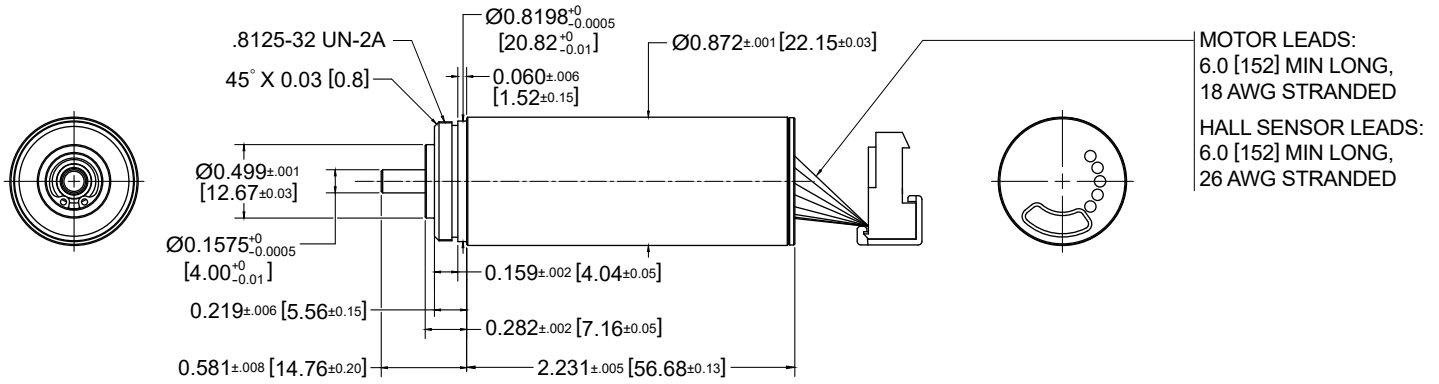

Dimensions in inches [mm]

Electrical Data	Symbol	SMX B0912N1016	Unit
1 Nominal Voltage	$U_N$	9.6	Volt
2 Optimization Direction	-	Bi-Directional	-
3 No Load Speed	$n_o$	38,633	rpm
4 Typical No Load Current	$I_o$	1053	mA
5 Max. Continuous Mechanical Power (@25°C)	$P_{max}$	112.5	W
6 Max. Continuous Current	$I_{cs}$	14.48	A
7 Max. Continuous Torque	$T_{cs}$	29.4 (4.16)	mNm (oz-in)
8 Back EMF Constant	$k_E$	0.248	V/1000 rpm
9 Torque Constant	$k_T$	2.37 (0.336)	mNm/A (oz-in/A)
10 Motor Regulation	$R/k^2$	7121	$10^3/Nms$
11 Peak Torque	$T_{pk}$	564.6 (80.0)	mNm (oz-in)
12 Motor Constant	$k_M$	11.84 (1.68)	mNm/W <sup>1/2</sup> (oz-in/W <sup>1/2</sup> )
13 Line to Line Resistance	$R_L$	0.040	ohms
14 Inductance Phase to Phase	$L$	0.009	mH
15 Mechanical Time Constant	$T_m$	2.63	ms
16 Electrical Time Constant	$T_e$	0.225	ms

General Data	Symbol	SMX B0912N1016	Unit
17 Gearhead Ratio	-	N/A	Ratio
18 Ambient Working Temperature Range	-	25 (77)	°C (°F)
19 Max Operating Temperature Range	-	155 (311)	°C (°F)
20 Radial Static Force w/o Shaft Support (max)	-	39.48	lbs
21 Axial Static Force w/o Shaft Support (max)	-	8.50	lbs
22 Thermal Resistance	$R_{th}$	10.0	°C/W
23 Thermal Time Constant	$T_w$	926	s
24 Weight	-	145 (5.11)	g (oz)
25 Rotor Inertia	$J_m$	24.7 (35.0)	kg-cm <sup>2</sup> 10 <sup>-4</sup> (oz-in-sec <sup>2</sup> 10 <sup>-6</sup> )
26 Hall Sensor Electrical Phasing	-	60	Electrical °

- Notes:**
- Three phase motor with Wye connections
  - Hall sensors: supply voltage 4.5 V - 24 V
  - Typical housing material 303 SS
  - Motor type has been designed and tested to achieve the stated number of autoclave cycles
  - Above parameters specified for 25° C ambient temperature
  - Typical shaft material 17-4 PH

Wire	Description
Blue	Phase A
Brown	Phase B
Violet	Phase C
Red	4.5 to 24 Vdc
Yellow	Hall 1
Orange	Hall 2
White	Hall 3
Black	Supply RTN

